

Tests of a Prototype Multiplexed Fiber-Optic Ultra-fast FADC Data Acquisition System for the MAGIC Telescope

H. Bartko, F. Goebel, R. Mirzoyan, W. Pimpl and M. Teshima

Max-Planck-Institut für Physik, Föhringer Ring 6, 80805 Munich, Germany

Presenter: H. Bartko (hbartko@mppmu.mpg.de), ger-bartko-H-abs1-og27-poster

Ground-based Atmospheric Air Cherenkov Telescopes (ACTs) are successfully used to observe very high energy (VHE) gamma rays from celestial objects. The light of the night sky (LONS) is a strong background for these telescopes. The gamma ray pulses being very short, an ultra-fast read-out of an ACT can minimize the influence of the LONS. This allows one to lower the so-called tail cuts of the shower image and the analysis energy threshold. It could also help to suppress other unwanted backgrounds.

Fast 'flash' analog-to-digital converters (FADCs) with GSamples/s are available commercially; they are, however, very expensive and power consuming. Here we present a novel technique of Fiber-Optic Multiplexing which uses a single 2 GSamples/s FADC to digitize 16 read-out channels consecutively. The analog signals are delayed by using optical fibers. The multiplexed (MUX) FADC read-out reduces the cost by about 85% compared to using one ultra-fast FADC per read-out channel.

Two prototype multiplexers, each digitizing data from 16 channels, were built and tested. The new system will be implemented for the read-out of the 17 m diameter MAGIC telescope camera.

1. Introduction

MAGIC is the world-wide largest Imaging Air Cherenkov Telescope (IACT). It aims at studying gamma ray emission from the high energy phenomena and the violent physics processes in the universe, at the lowest energy threshold among existing IACTs [2]. The camera of the MAGIC Telescope consists of 576 Photomultiplier tubes (PMTs), which deliver via an analog-optical link about 2 ns FWHM fast pulses to the experimental control house [4]. The currently used read-out system [1] is relatively slow (300 MSamples/s). To record the pulse shape in detail, an artificial pulse stretching to about 6.5 ns FWHM is used. This causes more light of the night sky to be integrated, which acts as additional noise. Thus the analysis energy threshold of the telescope is limited, and the selection efficiency of the gamma signal from different backgrounds is reduced.

For the fast Cherenkov pulses (2 ns FWHM), a FADC with 2 GSamples/s can provide at least four sampling points. This permits a reasonable reconstruction of the pulse shape. Monte Carlo (MC) based simulations predict different time structures for gamma and hadron induced shower images as well as for images of single muons. The timing information is therefore expected to improve the separation of gamma events from the background events [3]. Such an ultra-fast read-out can improve the performance of MAGIC. The improved sensitivity and the lower analysis energy threshold will extend the observation range of MAGIC, and allow one to search for weak sources at high redshifts.

A few FADC products with ≥ 2 GSamples/s and a bandwidth ≥ 500 MHz are available commercially; they are, however, very expensive and power-consuming. To reduce the cost of an ultra-fast read-out system, a 2 GSamples/s read-out system has been developed at the Max-Planck-Institut für Physik in Munich. It uses the novel technique of Fiber-Optic Multiplexing [10], an approach possible because the signal duration (few ns) and the trigger frequency (typically ~ 1 kHz) result in a very low duty cycle for the digitizer. The new technique uses a single FADC of 700 MHz bandwidth, 10 bit resolution and of 2 GSamples/s to digitize 16 read-out channels consecutively. The analog signals are delayed by using optical fibers. A trigger signal is generated using a fraction of the light, which is branched off by fiber-optic light splitters before the delay

fibers. All optical components and the FADCs are commercially available, while the multiplexer electronics has been developed at the MPI in Munich.

2. The Ultra-fast Fiber-Optic MUX-FADC Data Acquisition System

The basic idea of the MUX-FADC system is to “pack” the signals of many channels into a single FADC channel. The block diagram of the MUX-FADC system is shown in figure 1. The ultrafast fiber-optic multiplexer consists of three main components: fiber-optic delays and splitters, multiplexer electronics (fast switches and controllers) and ultra-fast FADCs.

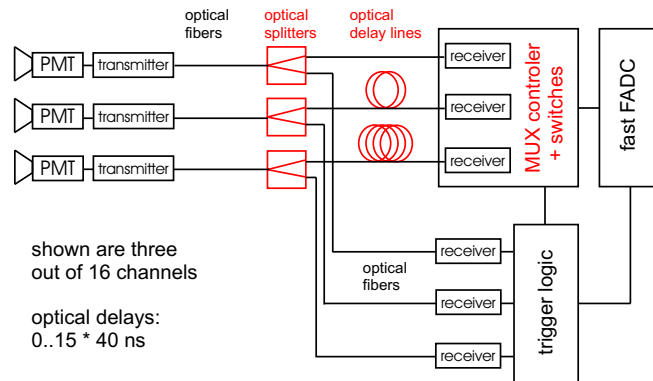

Figure 1. Schematic diagram of the multiplexed fiber-optic ultra-fast FADC read-out. See text.

After the analog optical link between the MAGIC PMT camera and the counting house the optical signals are split into two parts. One part of the split signal is used as an input to the trigger logic. The other part is used for FADC measurements after passing through a fiber-optic delay line of a channel-specific length.

The multiplexer electronics allows only the signal of one channel at a time to pass through and be digitized by the FADC. The other channels are attenuated by more than 60 dB for the fast MAGIC signals. In this way one “packs” signals from different channels in a time sequence which can be digitized by a single FADC channel.

Because of the finite rise and fall times of the gate signals for the switches and because of some pick-up noise from the switch one has to allow for some switching time between the digitization of two consecutive channels. The gating time for each channel was set to 40 ns, of which the first and last 5 ns are affected by the switching process. For the use in MAGIC a $16 \rightarrow 1$ multiplexing ratio was chosen. 16 channels are read out by a single ultra-fast FADC channel. The technological part of the fiber-optic multiplexer is described in detail in reference [10].

3. Prototype Test in the MAGIC Telescope on La Palma

Two prototype MUX-FADC read-out modules for 32 close packed channels were tested as a read-out of the MAGIC telescope during two weeks in August/September 2004. They were integrated into the MAGIC read-out system allowing the simultaneous data taking with the current 300 MSamples/s read-out and the MUX-FADC prototype read-out. In order to acquire only events where the shower image is located in the 32 MUX-FADC channels, only these channels were enabled in the MAGIC trigger system.

In figure 2a one can see the pulse shape in a single pixel for a typical cosmic event. By overlaying the recorded FADC samples of many events after adjusting to the same arrival time, the average reconstructed pulse shapes can be calculated. Figure 2b shows the comparison of the average reconstructed pulse shapes recorded with the current 300 MSamples/s MAGIC FADCs, including the 6ns pulse stretching, and with the MUX-FADCs. The average reconstructed pulse shape for cosmic events has a FWHM of about 6.3 ns for the current FADC system and a FWHM of about 3.2 ns for the MUX-FADC system.

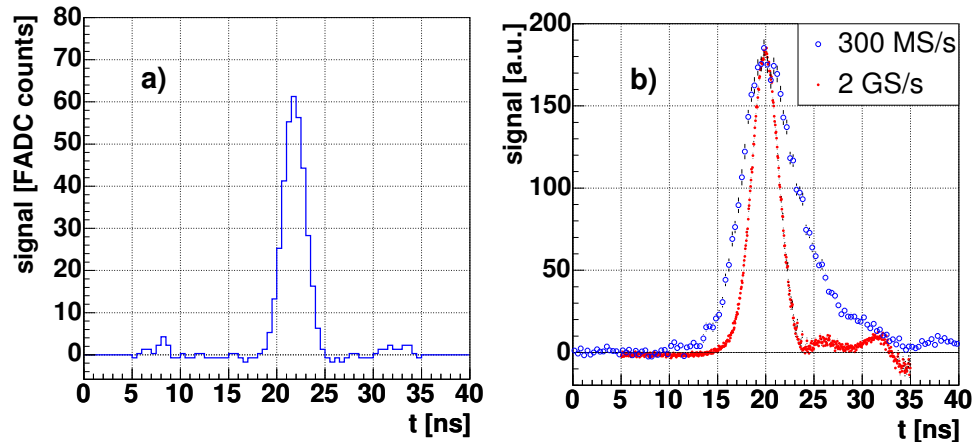

Figure 2. a) Pulse shape in a single pixel for a typical cosmic event after pedestal subtraction. b) Comparison between the mean reconstructed pulse shapes recorded with the current MAGIC FADCs (open circles) and with the MUX-FADCs (full points).

For the signal reconstruction a fixed number of FADC samples is integrated. The integration interval was chosen to be 4 FADC samples (corresponding to $4 \times 3.33 \text{ ns} = 13.33 \text{ ns}$) for the current MAGIC FADCs. For the MUX-FADCs a window size of 10 FADC samples is chosen, corresponding to a 5 ns integration window [7, 10]. The arrival time was calculated as the first moment of the FADC samples used for the charge integration.

The shorter integration time used for the pulse reconstruction with the MUX-FADC system yields a reduction of the effective integrated noise by about 40% for the MUX-FADC system compared to the current FADC system. Using the new MUX-FADC system the noise contributions due to the LONS may even be resolved into individual LONS pulses. Thereby a single photo electron spectrum could be obtained and used for in-situ calibration.

The MAGIC camera can be isochronously and uniformly illuminated by intensity controlled fast LED light pulsers of different colors [8]. The event to event variation of the timing difference between two read-out channels for the LED pulser provides a measure of the timing accuracy. The timing accuracy strongly depends on the signal to noise ratio and the width of the input light pulse. The MUX-FADCs yield a better timing resolution (0.35 ns) by more than a factor of three compared to the current FADC (1.3 ns) system using the simple and stable timing extraction algorithm. Even better timing resolutions may be achieved with dedicated algorithms that fit the pulse shape [7].

4. Discussion

The ultra-fast fiber-optic multiplexed FADC prototype read-out system was successfully tested during normal observations of the MAGIC telescope in La Palma. The ultra-fast FADC read-out has grown to a mature technology which is ready for the use as a standard read-out system for the MAGIC telescope and other high-speed data acquisition applications.

The MUX-FADC read-out reduces the costs by about 85% compared to using one ultra-fast FADC per read-out channel. Also the power consumption of the read-out system is greatly reduced.

The ultra-fast MUX-FADC system allows to use a shorter integration window for the Cherenkov pulses. The reduction of the pulse integration window from 13.33 ns (4 samples with 3.33 ns per sample) for the current MAGIC FADC system to 5 ns (10 samples with 0.5 ns per sample) for the MUX-FADC system corresponds to a reduction of the integrated LONS charge by a factor of about 2.7. Consequently, the RMS noise of the LONS is reduced by about 40%.

A reduction in the noise RMS translates into lower image cleaning levels [10], a larger part of the shower image (a shower image of a higher signal to noise ratio) can be used to calculate Hillas parameters [9]. This is especially important for low energy events where the signals of only a few pixels are above the image cleaning levels. This will allow the reduction of the analysis energy threshold of the MAGIC telescope.

The ultra-fast FADC system also provides an improved resolution of the timing structure of the shower images. As indicated by MC simulations [3] gamma showers, cosmic ray showers and the so called single muon events have different timing structures. Thus the ultra-fast FADC read-out can enhance the separation power of gamma showers from backgrounds.

After the successful prototype test of the ultra-fast MUX-FADC read-out system it is ready to be installed as a future read-out of the MAGIC telescope.

5. Acknowledgments

The authors thank R. Maier and T. Dettlaf from the electronics workshop of MPI. We also acknowledge the very good collaboration with the companies Acqiris and Sachsenkabel.

References

- [1] F. Goebel et al. (MAGIC Collab.), in *Proceedings of the 28th ICRC*, Tokyo, 2003.
- [2] C. Baixeras et al. (MAGIC Collab.), *Nucl. Instrum. Meth.* **A518** (2004) 188.
- [3] R. Mirzoyan et al., to be published in proceedings of the conference *Towards a Network of Atmospheric Cherenkov Detectors VII*, 27-29 April 2005 Palaiseau, France.
- [4] D. Paneque et al. (MAGIC Collab.), in *Proceedings of the 28th ICRC*, Tokyo, 2003.
- [5] R. Mirzoyan et al., *IEEE Trans. Nucl. Sci.* **49** (2002) 2473 .
- [6] R. Mirzoyan, J. Cortina and E. Lorenz, in *Proceedings of the 27th ICRC*, Hamburg, 2001.
- [7] H. Bartko et al. (MAGIC Collab.), to be published in proceedings of the conference *Towards a Network of Atmospheric Cherenkov Detectors VII*, 27-29 April 2005 Palaiseau, France, astro-ph/0506459.
- [8] M. Gaug et al. (MAGIC Collab.), to be published in proceedings of the conference *Towards a Network of Atmospheric Cherenkov Detectors VII*, 27-29 April 2005 Palaiseau, France.
- [9] A. M. Hillas, in *Proceedings of the 19th ICRC*, La Jolla, 1985.
- [10] H. Bartko et al., *Nucl. Instrum. Meth.*, in press, astro-ph/0505204.