

The AMS-02 Electronics System

A. Lebedev for the AMS02 Collaboration

Massachusetts Institute of Technology, Cambridge MA, USA

Presenter: A. Lebedev (alexei.lebedev@cern.ch), swi-lebedev-A-abs1-og15-oral

AMS is a precision TeV spectrometer in space. It is constituted of different detectors which require ~300,000 electronic channels that deliver 7 GBits/sec of data. The electronics is being built and tested to measure the time of flight to an accuracy of ~100 ps, to resolve the 200,000 tracker coordinates to an accuracy of 10 microns, to provide amplitude based discrimination of X-rays from charged particles in the 5,248 Transition Radiation Detector channels, to measure from single to 10,000 photons in each of the 21,760 Ring Imaging Cherenkov counter channels and to measure the 2,952 Electromagnetic Calorimeter channels with a dynamic range of 60,000.

1. Introduction

AMS-02 is a precision TeV particle spectrometer manifested for a three (or more) year mission on the International Space Station (ISS) [1]. For the electronics, AMS-02 has taken the high performance technologies used in particle physics and implemented them for use in low Earth orbit. A unified approach has been made to meet the requirements imposed by the different AMS subdetectors, by NASA and by the physics goals. Particular effort has been made to ensure that the data acquisition and trigger electronics will meet the performance requirements on orbit during the 3+ years of operation. Meeting the challenges of implementing high performance, space qualified electronics is a key activity of the entire AMS collaboration.

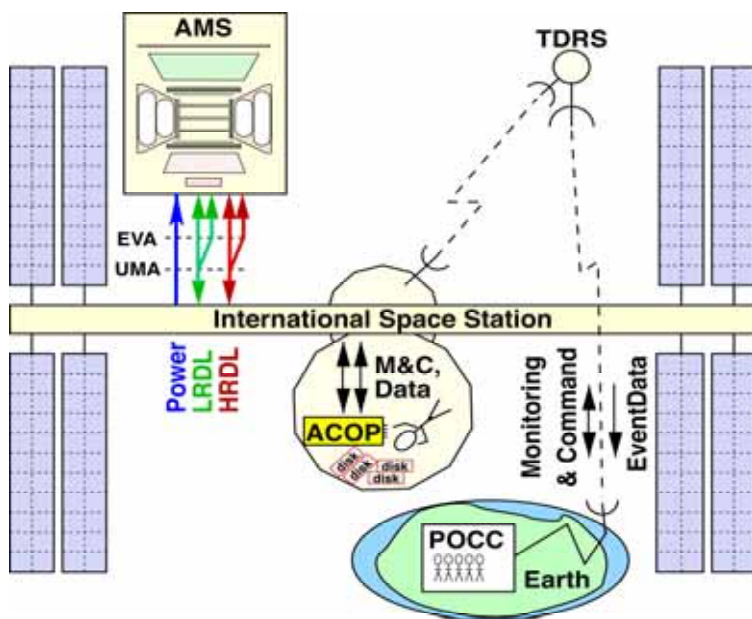

Figure 1. AMS electrical interfaces on ISS (TDRS: Tracking and Data Relay Satellite, POCC: Payload Operations and Control Center, M&C: Monitoring and Command).

2. Interfaces

Fig. 1 indicates the NASA provided interfaces on the ISS: power, Low Rate Data Link (LRDL) and High Rate Data Link (HRDL). ISS solar arrays provide AMS with less than 3 KW of power at 120 VDC with very stringent electromagnetic compatibility requirements. The LRDL is based on the MIL-STD-1553B dual serial bus and is used by AMS for commanding and monitoring. The available data rate is ~10Kbit/s with duty cycle of 55 to 90%. Critical health data are transmitted continuously at 10byte/s. At most one 120 byte command is allowed each second. The HRDL runs over fiber optic cables at 125 MBaud. This data stream consists of the event data and a copy of the monitoring data. Within the ISS, the AMS Crew Operation Post (ACOP) computer records all the data on hard disks. The downlink of all AMS data is performed on the Ku-band via TDRS satellites to the ground, through NASA centers and the Internet to the AMS-02 Payload Operations and Control Center (POCC) in real time. ACOP can also play back the recorded data if necessary. The allocated downlink bandwidth for AMS-02 is 2 Mbit/s on average.

3. Subdetector Requirements

The Transition Radiation Detector (TRD) discriminates high-energy positrons from protons (as well as positrons from antiprotons). It consists of 5,248 proportional wire straw tubes in which the gas gain control is critical.

The silicon tracker measures the trajectory of passing charged particles to 10 microns and the particle charge in 192 ladder elements with 1024 readout strips each. The signals are as small as a few femtocoulombs.

The Time of Flight (TOF) system has four scintillator planes with 144 PMTs. To measure the particle velocity, the relative time of passage through different paddles is required with 100 picosecond accuracy. The energy deposited is also measured. The AntiCoincidence Counters (ACC) have 16 PMTs. Together these scintillators provide the primary trigger for the AMS-02 experiment.

The Ring Imaging Cherenkov Counter (RICH) identifies particles by measuring the location and number of photons collected by 680 16-pixel PMTs. The dynamic range of each pixel channel is about 10,000.

The Electromagnetic Calorimeter (ECAL) discriminates between electrons and hadrons by the shower shape and energy measured in 324 4-pixel PMTs with a dynamic range of 60,000. The ECAL also provides a trigger signal for $> 2\text{GeV}$ gammas.

In total there are about 227,300 channels, and each channel provides 16 bits of information for each event with trigger rates up to 2 kHz. The resulting raw data rate is over 7 Gbit/s. The electronics reduces the event size and filters out mistriggers to reach the allocated 2 Mbit/s downlink data rate.

4. The DAQ Chain

Though the detailed requirements imposed by the physics are different for each of subdetectors, a unified approach was adopted for their electronics, based on the successful experience gained with the AMS-01 engineering flight updated for new technologies. This approach is shown in Fig. 2. Analog signals from the detectors enter a detector specific Application Specific Integrated Circuit (ASIC) and are first shaped and then held in response to a trigger, the trigger having been generated using signals from some of the detectors. The held signals are then multiplexed with the ASIC. These are mounted close to the detector elements.

Before or after digitization, typically with an ADC, the output is then sent over a cable into a CDP (Common Digital Part) and buffered into memories. With multiplexing, each CDP collects data from up to 1000 different subdetector signals. A unified approach was also applied to the monitoring and control (M&C) of the subdetector parameters and to their power supplies.

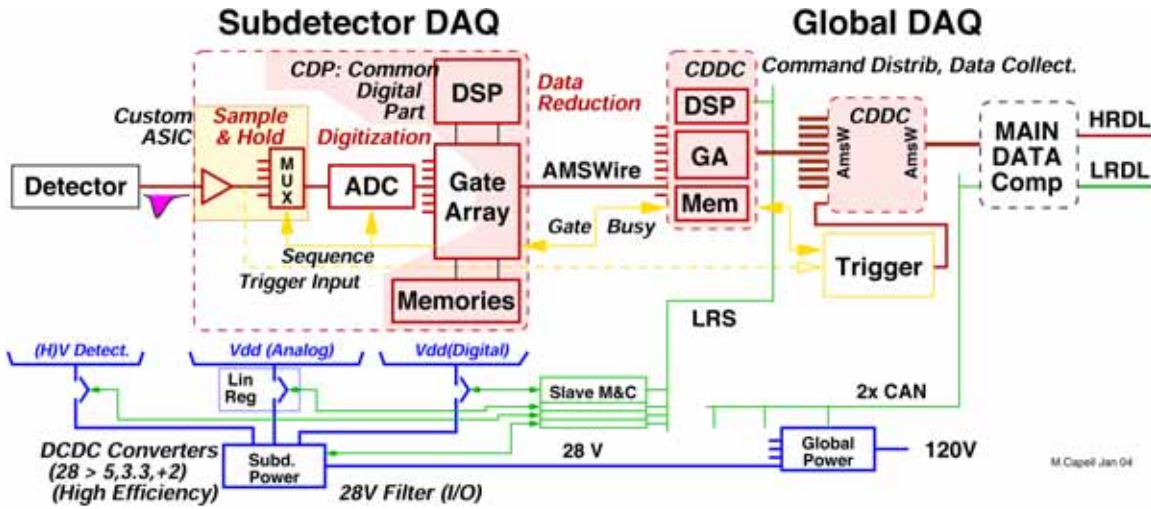

Figure 2. Unified approach to subdetector electronics for DAQ, Monitoring and Control (M&C) and power.

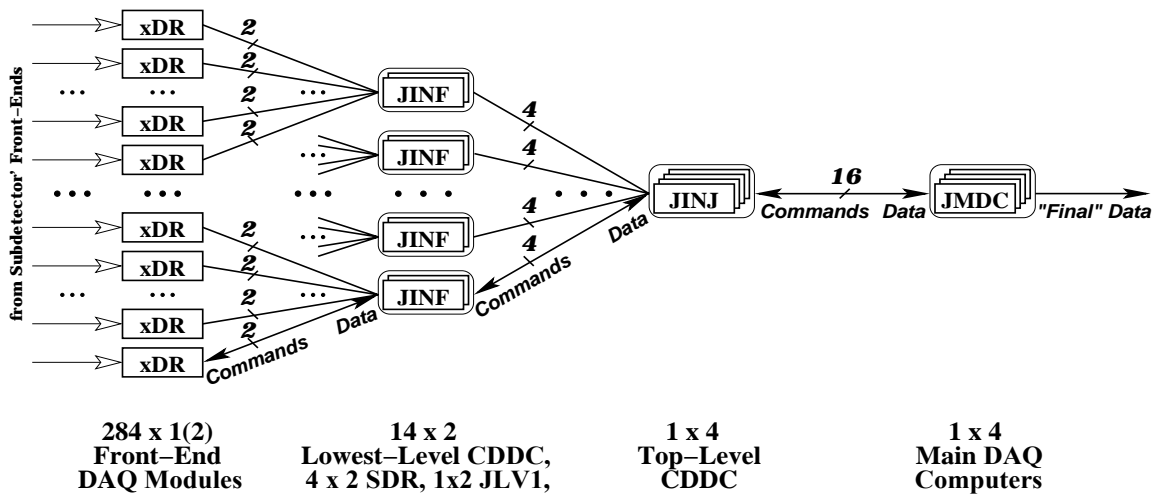

Figure 3. The DAQ tree. The number of redundant nodes at each level is shown.

The DAQ system tree is shown on Fig.3. The physics data flow in the electronics is driven by the trigger system, which recognizes when a charged particle has passed through the detector based on the coincidence of fast signals from the TOF counters and no ACC signals are detected. The predicted total trigger rate (estimated from AMS-01 measurements) varies from 200 to 2000 Hz, depending on the geomagnetic latitude. The electronics system is being conservatively designed to run at twice these rates. Technically, two CDPs are located on one xDR board, where x=E, R, S, T, U for the different subdetectors. For the RICH and Tracker, x=R, T, the two CDPs are independent. For the ECAL, Scintillators and TRD, x=E, S, U, the two CDPs are in cold redundancy. In all cases, once the raw data is stored into memory, the following DAQ circuitry is the same for all the subdetectors. Asynchronously with subsequent triggers, the data within a CDP is reduced using a subdetector specific algorithm in a digital signal processor (DSP) and rebuffered.

When resources are available to receive it, this DSP output is shipped over a custom developed 10 MByte/sec serial link, AMSWire, into the global data acquisition tree. The next node in this tree, a Command Distributor and Data Concentrator (CDDC) circuit located on a JINF board, receives data from up to 24 CDP. The CDDC is in fact a CDP with modified front end and larger memories. In the CDDC the data from an event is collated, buffered and, again using AMSWire links, sent to the top level CDDCs located on JINJ boards, collated, buffered and in turn passed into a JMDC. The JMDC receives the complete event and analyses it to ensure that it might contain interesting physics and also to monitor the detector performance. The selected events are then buffered and sent out over the HRDL when it becomes available.

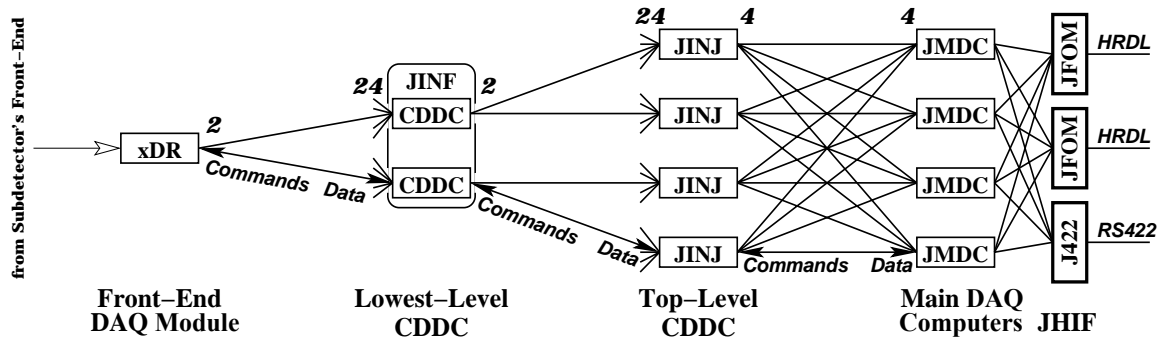

Figure 4. The DAQ tree. The number of redundant nodes at each level is shown.

The extensive use of point to point serial links has made it straight forward to implement progressively higher levels of redundancy as the data travels higher up the DAQ tree, as shown in Fig. 4.

5. Status and Conclusions

All of the components and circuits used in these unified approaches have gone through a rigorous process to ensure that they will meet the performance requirements and operate reliably in outer space. Various tests of components and assembled boards have been performed: vibration, radiation, thermal, thermal-vacuum, etc. The serial production of most of the flight boards has been started at CSIST, Taiwan, and will be completed this year.

6. Acknowledgements

We want to thank the many organizations and individuals listed in the acknowledgements of ref [1].

References

- [1] C. Lechanois-Leluc, "AMS – A magnetic spectrometer on the International Space Station", these proceedings.