

The 2004 BESS-Polar scientific flight in Antarctica

T. Yoshida^a, J. W. Mitchell^b, A. Yamamoto^a, K. Abe^{c*}, H. Fuke^d, S. Haino^a, T. Hams^b, K. C. Kim^e, T. Kumazawa^a, M. H. Lee^e, Y. Makida^a, S. Matsuda^f, H. Matsumoto^f, K. Matsumoto^a, A. A. Moiseev^b, Z. D. Myers^e, J. Nishimura^f, M. Nozaki^c, A. Ogata^c, M. Oikawa^c, J. F. Ormes^b, M. Sasaki^b, E. S. Seo^e, Y. Shikaze^{c†}, R.E. Streitmatter^b, J. Suzuki^a, K. Takeuchi^c, K. Tanaka^a, T. Taniguchi^a, T. Yamagami^d and K. Yoshimura^a

(a) High Energy Accelerator Research Organization (KEK), Tsukuba, Ibaraki, 305-0801 Japan

(b) NASA Goddard Space Flight Center (NASA/GSFC), Greenbelt, MD 20771 USA

(c) Kobe University, Kobe, Hyogo, 657-8501

(d) Institute of Space and Astronautical Science (ISAS/JAXA), Sagami-hara, Kanagawa, 229-8510 Japan

(e) University of Maryland, College Park, MD 20742 USA

(f) The University of Tokyo, Bunkyo, Tokyo, 113-0033 Japan

Presenter: T. Yoshida (tetsuya.yoshida@kek.jp), jap-yoshida-T-abs1-og11-oral

The first scientific flight of the BESS-Polar experiment was carried out in December 2004, aiming at elementary particle phenomena in the early Universe through observation of low energy antiprotons and search for antimatter in the cosmic radiation. The BESS-Polar payload was launched on December 13 from Williams Field near the US McMurdo Station in Antarctica, and circled around the South Pole for 8 days and 17 hours. During the flight, the superconducting spectrometer including the solar-cell power supply system worked well, and two terabytes scientific data were recorded on the onboard hard disk drives. The flight was terminated on December 21, and the payload landed on the Ross Ice Shelf. The recovery operation continued for a week, and the spectrometer was recovered safely.

1. Introduction

A low-energy antiproton energy spectrum measured by BESS (Balloon-borne Experiment with a Superconducting Spectrometer) in the last solar minimum period (Fig. 1) [1] was slightly flatter than the predictions of the antiproton production by collisions between high energy cosmic rays and interstellar matter. This might indicate the existence of novel processes of cosmic-ray antiproton in the Universe, such as evaporation of primordial black holes [2] or annihilation of supersymmetric dark matter [3]. A long duration balloon (LDB) flight over Antarctica can provide an excellent opportunity for a high statistical low-energy antiproton measurement, by which the origin of low energy antiprotons in the cosmic radiation can be concluded. It flies at the low geomagnetic cut-off region about 10 days for a single circumnavigation, so we can expect much higher statistics by one LDB Antarctic flight than that by a one-day conventional balloon flight.

A LDB flight is also suitable for the highly sensitive search for cosmic antimatter. Even a single event of antihelium nuclei in the cosmic radiation would have very important significance for both cosmology and

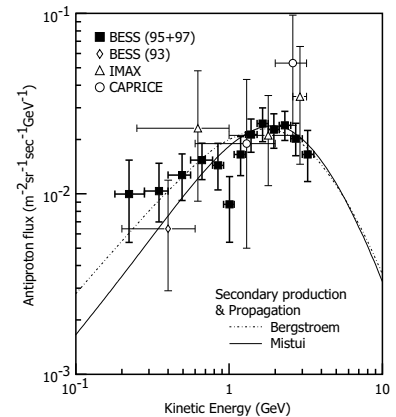

Figure 1. Low-Energy antiproton spectrum measured by BESS.

* Present address: Kamioka Observatory, ICRR, The University of Tokyo, Kamioka-cho, Gifu 506-1205 Japan

† Present address: Tokai Research Establishment, Japan Atomic Energy Research Institute, Tokai, Ibaraki 391-1195 Japan

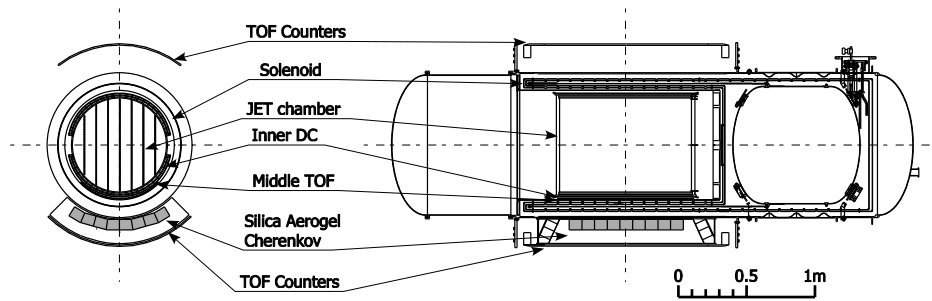

Figure 2. Cross-sectional views of the BESS-Polar payload.

particle physics, because it will be a strong evidence of the existence of antimatter domain in the Universe, which would have been generated by the “local” matter-antimatter asymmetry in the early Universe.

Thus the advanced phase of the BESS experiment, BESS-Polar, has been prepared since 2001 [4], for further investigation of the elementary particle phenomena in the early Universe through a precise measurement of an energy spectrum of low-energy cosmic-ray antiprotons and an extensive search for antimatter in the cosmic radiation.

2. BESS-Polar payload

In order to meet the severe requirements for the LDB flight over Antarctica, a completely new superconducting spectrometer was built for the BESS-Polar experiment. The basic concepts, such as the cylindrical configuration with an open and wide acceptance and redundant measurements of parameters for unambiguous particle identification, are inherited from the BESS superconducting spectrometer for the conventional balloon flights. The material thickness along the incident particle trajectories was minimized to measure lowest energy antiprotons down to 100 MeV at the top of the atmosphere. The total weight of the payload was also reduced to utilize a 39 MCF two-cap balloon, which can carry the payload into an altitude with the residual pressure less than 5 hPa.

The BESS-Polar spectrometer, as shown in Fig. 2, consists of a superconducting solenoid, a drift chamber tracking system, three time-of-flight (TOF) scintillator hodoscopes, a silica-aerogel Cherenkov counter, a data acquisition system and their power supply system. The detailed design is described in elsewhere [5].

The development of this new payload has progressed step by step. The basic concept of the solar-cell power system was verified by an engineering balloon flight at the Sanriku Balloon Center in Japan. The performance of the particle detectors, such as thinner TOF counters and silica aerogel Cherenkov counter, were verified with a beam test at the proton synchrotron at KEK. In October, 2003, a technical flight was conducted at Ft. Sumner, NM, U.S.A., in order to check the compatibility of the interfaces between the payload and the balloon vehicle. Although no particle detector was onboard, launching of the payload with the full-size structure, balloon operations in a strong magnetic stray field, and communication between the payload and the ground station via the TDRSS (Tracking and Data Relay Satellite System) were satisfactorily verified.

After the technical flight at Ft. Sumner, the final integration of the BESS-Polar payload was carried out at NASA Goddard Space Flight Center. All particle detectors were installed onto the superconducting spectrometer, and were checked their performance by cosmic-ray muons. In August 2004, a pre-deployment integration for the LDB flight was conducted at the National Scientific Balloon Facility (NSBF) in Palestine, TX. Certified by the



Figure 3. Balloon launch of the BESS-Polar payload.



Figure 4. Recovery operation on the ice.

mission readiness review in September 2004, BESS-polar was decided as a one of two payloads to be flown over Antarctica in the austral summer 2004/2005.

3. Scientific flight

The onsite preparation of the first BESS-Polar flight over Antarctica was conducted from the end of October, 2004. In a staging area, so-called ‘Weatherport’, at Williams Field near the U.S. McMurdo Station, the BESS-Polar spectrometer was finally integrated and checked for a month. The compatibility test on the ice was performed on December 3, and then the BESS-Polar payload became ready for the flight.

On December 13, 2004, the balloon carrying the BESS-Polar payload was launched from Williams Field (Fig. 3). The payload floated over Antarctica for more than 8 days in an altitude over 37 km. During the flight, the superconducting spectrometer including a solar-cell power supply system worked well, except for the malfunction of part of photomultipliers for the TOF counters placed in vacuum. Sometimes during the flight, since the payload went south beyond the line of sight of the TDRSS satellites, the communication between the payload and the ground stations was lost. But generally we could monitor and control our payload well, and could keep the payload in good condition.

The payload landed at the south end of the Ross Ice Shelf on December 21. The recovery operation onsite was carried out for a week. The payload and the solar panel structure were disassembled completely, and the cryostat of the superconducting solenoid was cut into several pieces, as shown in Fig. 4, in order to be accommodated by the DHC-6 Twin Otter recovery airplane.

Table 1. Flight summary of the 2004 BESS-Polar experiment.

Launch	0554Z, December 13, 2004 at 77° 51.8' S, 167° 5.4' E
Floating	0914Z, December 13, 2004 at 78° 4.8' S, 167° 25.2' E
Termination	2214Z, December 21, 2004 at 83° 17.4' S, 154° 20.4' W
Landing	2256Z, December 21, 2004 at 83° 6.0' S, 155° 35.4' W
Data acquisition duration	180 hours 7 minutes
Live time fraction over the DAQ duration	80.0 %
Number of cosmic-ray events	900 million
Total accumulated data size	2.14 terra bytes

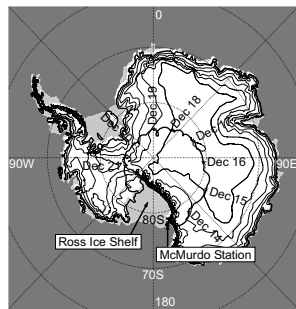

Figure 5. Flight trajectory of the 2004 BESS-Polar flight.

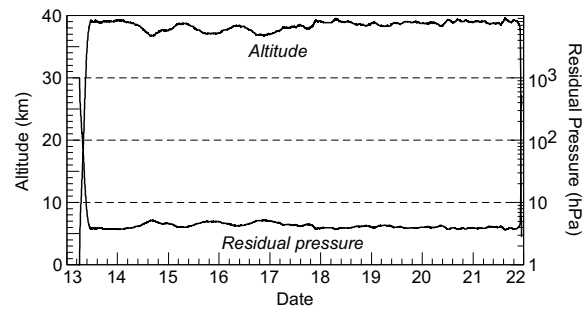

Figure 6. Altitude and residual pressure variation of the 2004 BESS-Polar flight.

The flight status is summarized in Table 1. The flight trajectory is shown in Fig. 5, and the altitude and the residual pressure variation during the flight are shown in Fig. 6.

4. Summary

The first scientific balloon flight of the BESS-Polar experiment was successfully carried out in the austral summer in 2004/2005. 900 million cosmic-ray events were recorded on the hard disk drives, and the drives were securely recovered. Though some of the particle detectors and the superconducting solenoid were disassembled on the ice due to the limited capacity of the recovery transportation, the BESS-Polar payload will be integrated again for a possible further flight by the LDB over Antarctica.

Acknowledgements

The authors thank Dr. W. V. Jones of NASA Headquarters for his continuous encouragement in this US-Japan cooperative project. Sincere thanks are expressed to the NASA Balloon Programs Office at GSFC/WFF and NSBF for their experienced support. We also thank ISAS and KEK for their continuous support and encouragement. Special thanks go to the National Science Foundation (NSF), U.S.A., and Raytheon Polar Service Company for their professional support in U.S.A. and in Antarctica.

The BESS-Polar experiment is being carried out as a Japan-U.S. collaboration, and is supported by a KAK-ENHI in Japan, and by NASA in U.S.A. The balloon flight operations were carried out by NSBF as part of NASA's scientific balloon program, and the activity in Antarctica was operated by the NSF.

References

- [1] T. Maeno et al., *Astroparticle Phys.* 16, 121 (2001), and references are therein.
- [2] M. S. Turner, *Nature* 297, 379 (1982).
K. Maki, T. Mitsui and S. Orito, *Phys. Rev. Lett.* 76, 3474 (1996).
- [3] F. W. Stecker, S. Rudaz and T. F. Walsh, *Phys. Rev. Lett.* 55, 2622 (1985).
- [4] A. Yamamoto et al., *Adv. Space Res.* 30(5), 1253 (2002), and references are therein.
- [5] T. Yoshida et al., *Proc. 28th ICRC*, Tsukuba, 2081 (2003).
T. Yoshida et al., *Adv. Space Res.* 33, 1755 (2004).